

GENERAL NOTES

- All dimensions and levels are to be checked on site prior to construction of the Works.
- Drawing must not be scaled. Report any discrepancies to the Architect prior to commencement.
- All construction & related scope work be carried out in accordance with the National Building Regulations.
- SANS 10400
- All foundations, retaining walls, piling & caps, slabs, beams, columns and agricultural drains to be constructed as per engineer's drawings and specifications.
- The main contractor to check the land surveyors drawings for confirmation of setting out levels and dimensions on site.
- Building work may only commence on approval of the building plans from the local authority.

NOTES IN RESPECT OF S.A NATIONAL STANDARD FOR THE APPLICATION OF NATIONAL BUILDING REGULATIONS SANS 10400

- PART A general principles and requirements**
All requirements to comply with Part A sans 10400
- PART B structural design**
All structural work as per rational design by engineer
- PART C dimensions**
All dimensions of any room or space to comply with the requirements of Part C sans 10400
- PART D public safety**
All balustrades to comply with D4.2 & D1 (annex a)
All ramps and driveways to comply with D4.3 & D3 (annex a) & D4 (annex c)
All swimming pools and swimming baths to comply with D4.4 & D4 (annex c)
- PART E site operations**
All site operations to comply with Part E sans 10400
- PART F excavations**
All excavations to comply with G4.1 & G4.2
- PART H foundations**
All foundations as per rational design by competent person to comply with Part H
- PART I floors**
All floors as per rational design by competent person to comply with Part I
- PART K walls**
All masonry walls to comply with K4.2 & K1 - K2 (annex a)
All lintels to comply with b1 (annex b) of Part K
Firing of roof to concrete elements to comply with K4.4 & K3 (annex a)
All waterproofing to walls to comply with K4.5 & C1 (annex c) of Part K
All fire performance and resistance of walls to comply with K4.6 & K4 (annex a)
- PART L structural walls**
All structural walls as per rational design by competent person to comply with Part L
- PART M roofs**
Roof as per rational design by competent person to comply with Part M
- PART N stairways**
All stairways to comply with M4.1
Dimensions of stairways to be in compliance with M4.2
All balustrades to comply with M4.3
- PART O glazing**
All glazing to comply with part N4 & N1 (Annex a)
- PART P lighting & ventilation**
All lighting and ventilation to comply with Part O4.1
All areas to be artificially and naturally lit to comply with Part O4.2 of sans 10400
- PART R drainage**
All pipe joints to comply with P4.2
All sanitary fixtures in accordance with P4.3, P4.4 & P4.5
All discharges from washing areas to comply with P4.7
All discharges from swimming baths, pools, fountains or reservoirs to comply with P4.10
All sanitary fixtures to be in accordance with P4.11
All drainage systems to comply with P4.13
All sizing of discharge pipes to comply with P4.14
All drain sizes shall comply with P4.15
All sanitary fixtures to have traps in accordance with P4.16
All sizing of ventilation pipes to comply with P4.17
All discharge & ventilating pipes to be installed in compliance with P4.18
Drains to be accessible in accordance with P4.19
All traps to be in accordance with requirements of P4.20
Gully to comply with requirements of P4.21
All drains to be laid in accordance with P4.22 & P4.23
- PART R storm water disposal**
All storm water as per rational design by competent person to comply with Part R
- PART T fire protection**
All materials to comply with T4.5
All structural elements & components to comply with T4.7
All openings to be protected in compliance with T4.10
Roof assemblies & coverings to comply with T4.12
All ceilings to comply with T4.13
All floor coverings to comply with T4.14
All wall finishes to comply with T4.15
Stairway to comply with T4.23
Portable fire extinguishers to be in accordance with T4.37 and to the satisfaction of the chief fire officer
Building materials to comply with T4.55 & T4.56
Fire protection for Buildings H1 & H4 to comply with T4.57
- PART V space heating**
All fire place and chimneys as per Part V of sans 10400
- PART XA energy usage in buildings**
All Energy Calculations as per rational design by competent person.

CONSTRUCTION NOTES:

- ROOF**
 - Zincalume type Roof sheeting (IBR) profile to be fixed as per manufacturer's specification on 50 x 76mm timber purlins at 900mm c/c on an approved underlay on 114 x 38 mm timber trusses on maximum 1500mm c/c to be designed by a professional roofing engineer.
 - 100mm aerolite blanket above ceiling.
 - all flat roof sections to have screeding to sufficient falls, to full bore outlets.
 - all flat roof sections to be torch waterproofed by specialist.
 - underside of r.c. slabs to be plastered and painted.
 - detail specification of all flat slabs as per energy efficiency report.
 - rainwater gutters to be seamless aluminium with colour to match roof sheeting (unless otherwise specified)
 - rainwater downpipes to be upvc painted to match wall colour.
- WALLS**
 - all plaster work to be rendered smooth, unless otherwise stated.
 - all external brickwork to have outside face of internal brick skin bagged and bituminised.
 - two courses brick force to be provided at slab, sill and wall plate level.
 - brick force to be provided every 3 courses.
 - p.c. lintols to be provided above all openings.
- FLOOR**
 - ground floor: mesh reinforced concrete surface bed, to be certified by an engineer, on approved damp proof membrane on well compacted and poisoned soil.
 - first floor: suspended reinforced concrete slab to pr. eng. detail.
- FOUNDATIONS**
 - all foundations to pr. engineers detail.
- MECHANICAL VENTILATION:**
 - fresh air supply of 7.5 l/s/pp
 - even air distribution
 - maximum air velocity 0.5m/s
 - internal bathrooms - air to me extracted to the external of the building at a rate of 25 l/s/per bathroom.

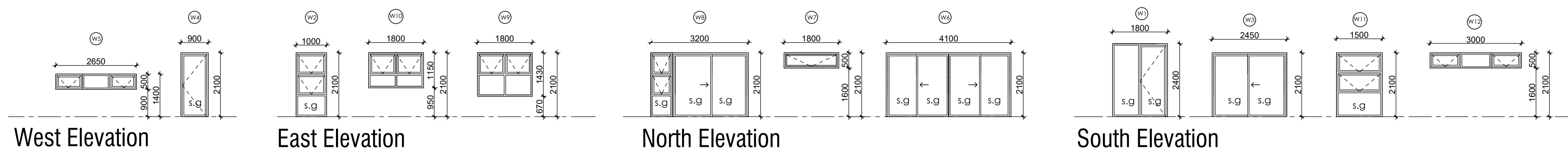

Window Schedule
SCALE 1:100

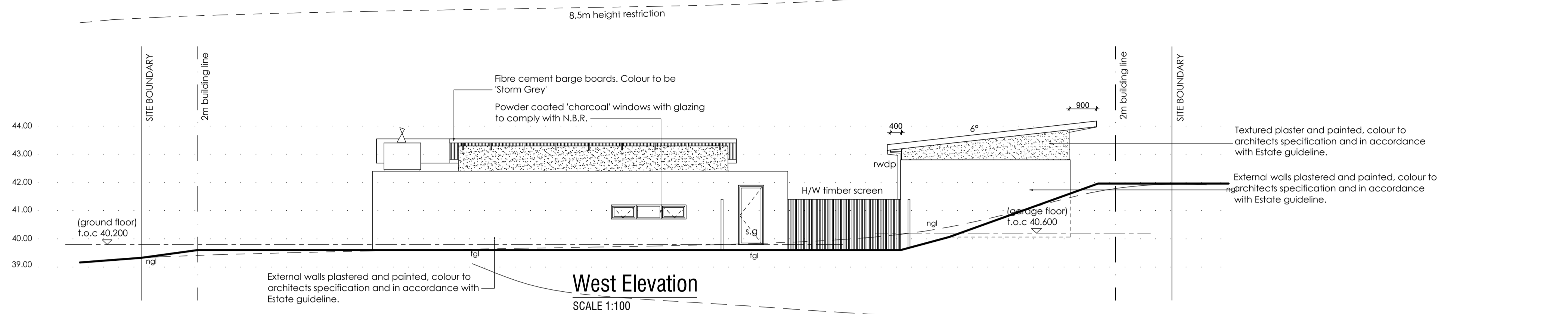

West Elevation
SCALE 1:100

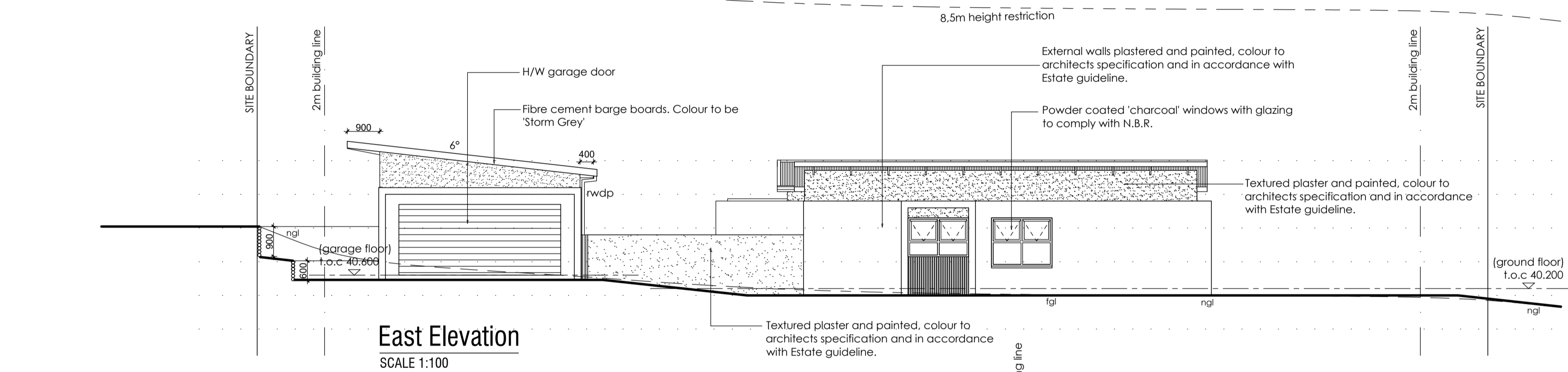

East Elevation
SCALE 1:100

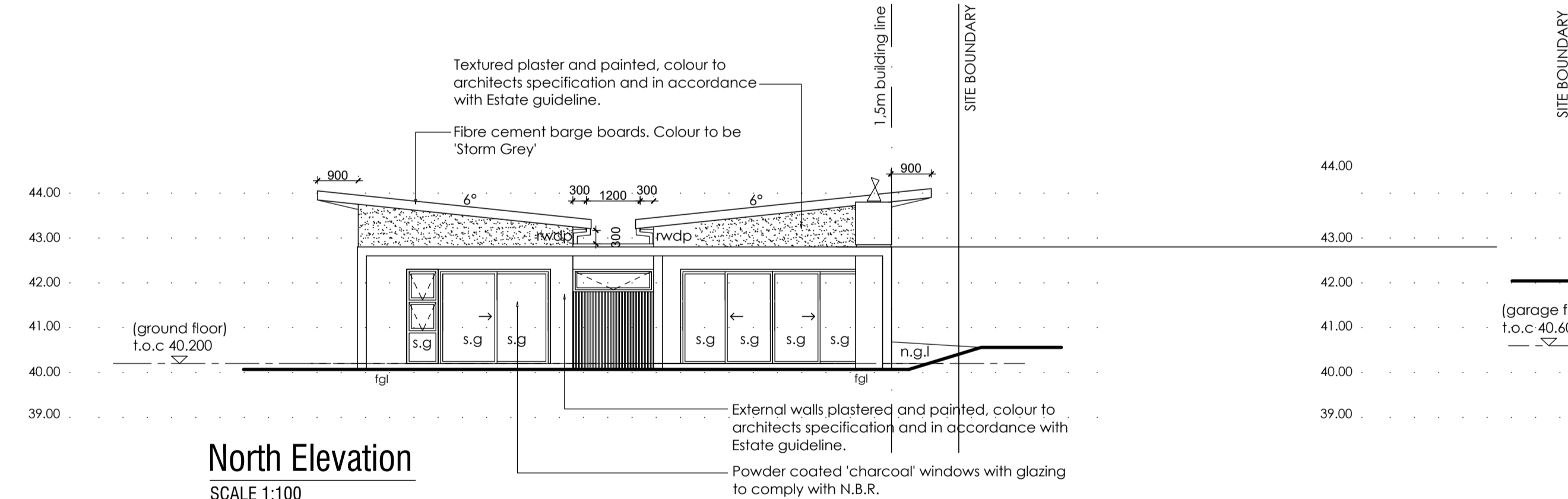

North Elevation
SCALE 1:100

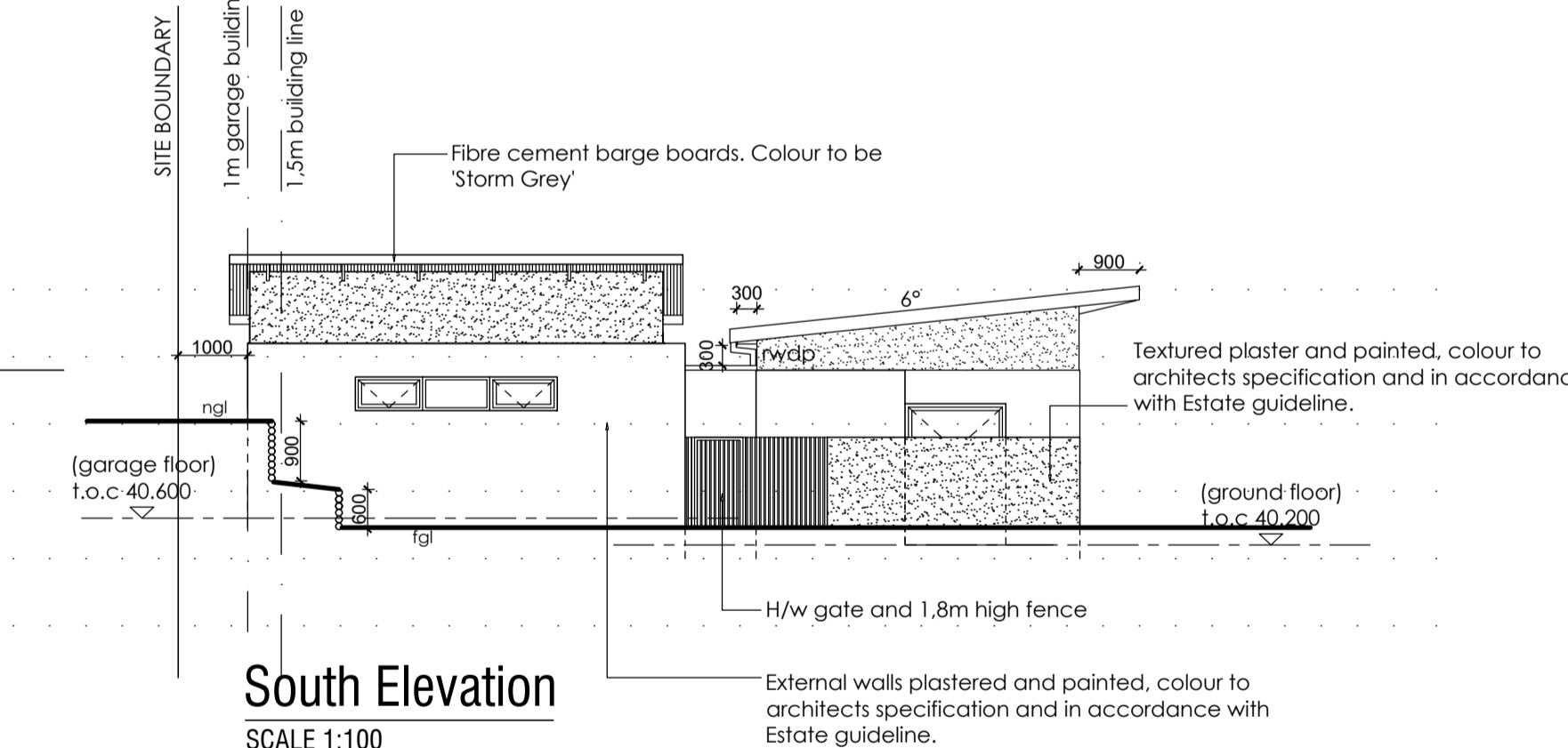

South Elevation
SCALE 1:100

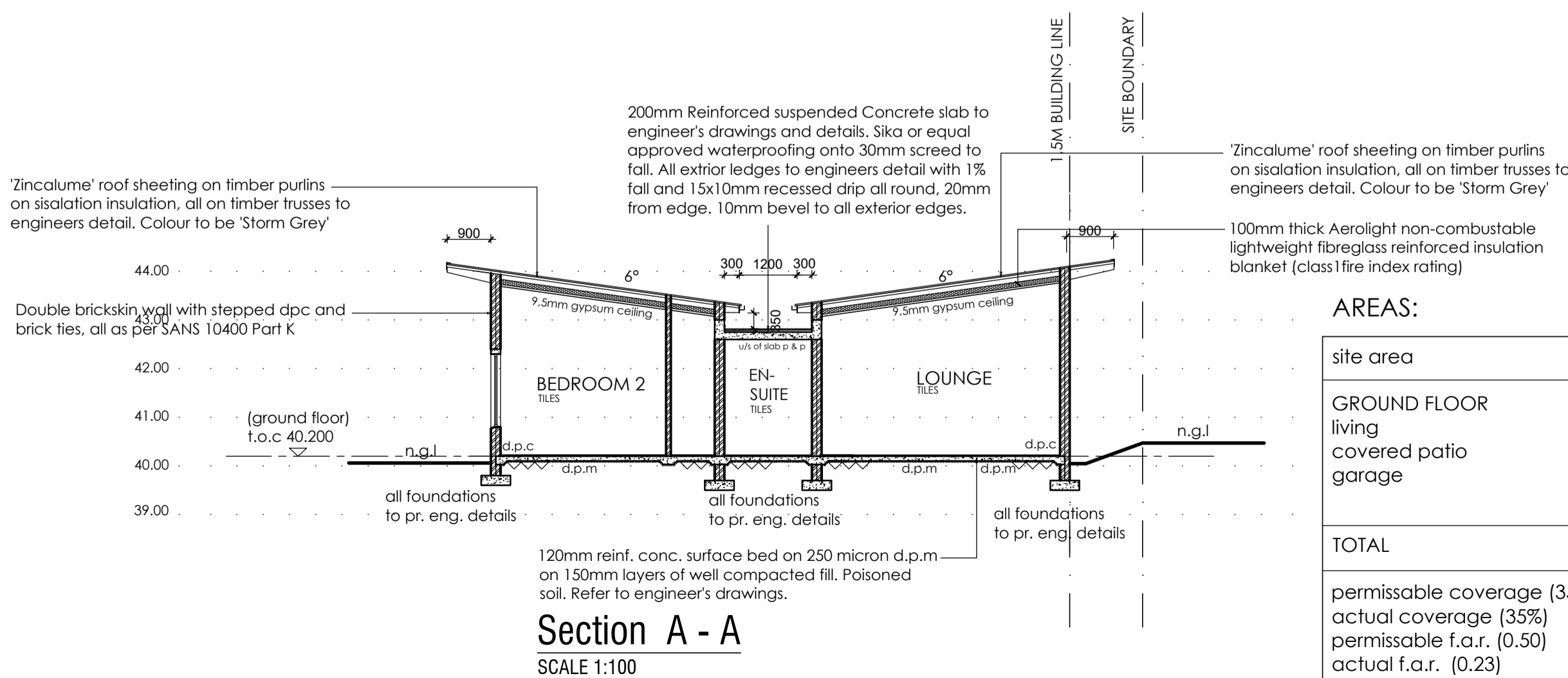

Section A - A
SCALE 1:100

AREAS:

site area	1456.0 sqm
GROUND FLOOR	
living	345.50 sqm
covered patio	52.20 sqm
garage	111.90 sqm
TOTAL	509.60 sqm
permissible coverage (35%)	509.60 sqm
actual coverage (35%)	509.60 sqm
permissible f.a.r. (0.50)	728.00 sqm
actual f.a.r. (0.23)	345.50 sqm

Drive way Section
SCALE 1:100

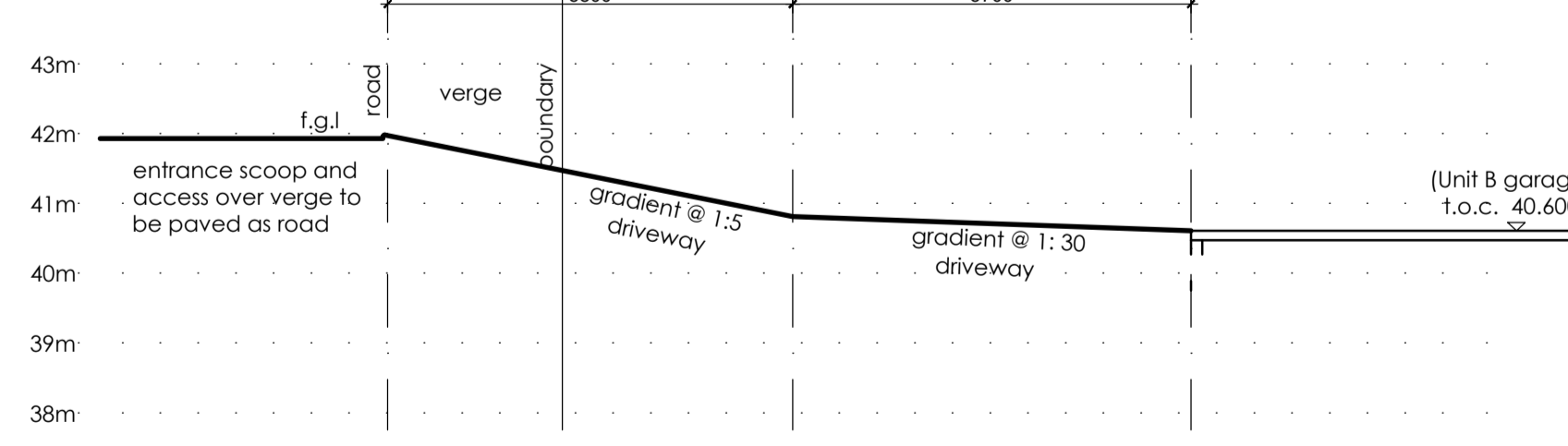

FINISHES KEY:

PLASTER AND PAINT MAIN HOUSE	PLASCON SPRINGBOK CHEST Y3-C2-2
PLASTER AND PAINT FEATURE WALLS	PLASCON GOLD ESTATE Y2-D1-3
PLASTER AND PAINT ABOVE WALL PLATE	PLASCON OLD COBBLESTONE Y2-D1-4
ALUMINIUM ROOF SHEETING	STORM GREY
NTINGU FENCE	NATURAL
ALUMINIUM WINDOWS	POWDER COATED CHARCOAL



SACAP Professional: 6214 | pieter.apic@gmail.com |
Tel: 071 767 2196
Postnet Suite 316, Private Bag X0001, Ballito. 4420

Date _____
Architect Signature _____

**PROPOSED NEW 3 UNIT
RESIDENTIAL DEVELOPMENT
on
Lot 639, Palm Lakes Estate
for
VW INVESTMENTS (PTY) LTD**

36 Lake Great Bear Avenue

Occupancy Classification: H3

**UNIT A ELEVATIONS &
SECTIONS**

P.H	Checked	P.H	Date
21.73	002		AUG 21