



THE KINGSLEY

secure private estate



EXQUISITE
URBAN LIVING



THE KINGSLEY

secure private estate

36 Luxury Designer Family Homes
in a Secure Private Estate

Situated Corner of Frederick &
Christine Roads, Fourways

Selection of four Home Types with
Sophisticated Finishes & Fixtures

Gatehouse with Access Control &
State-of-the-art Security

Landscaped Gardens

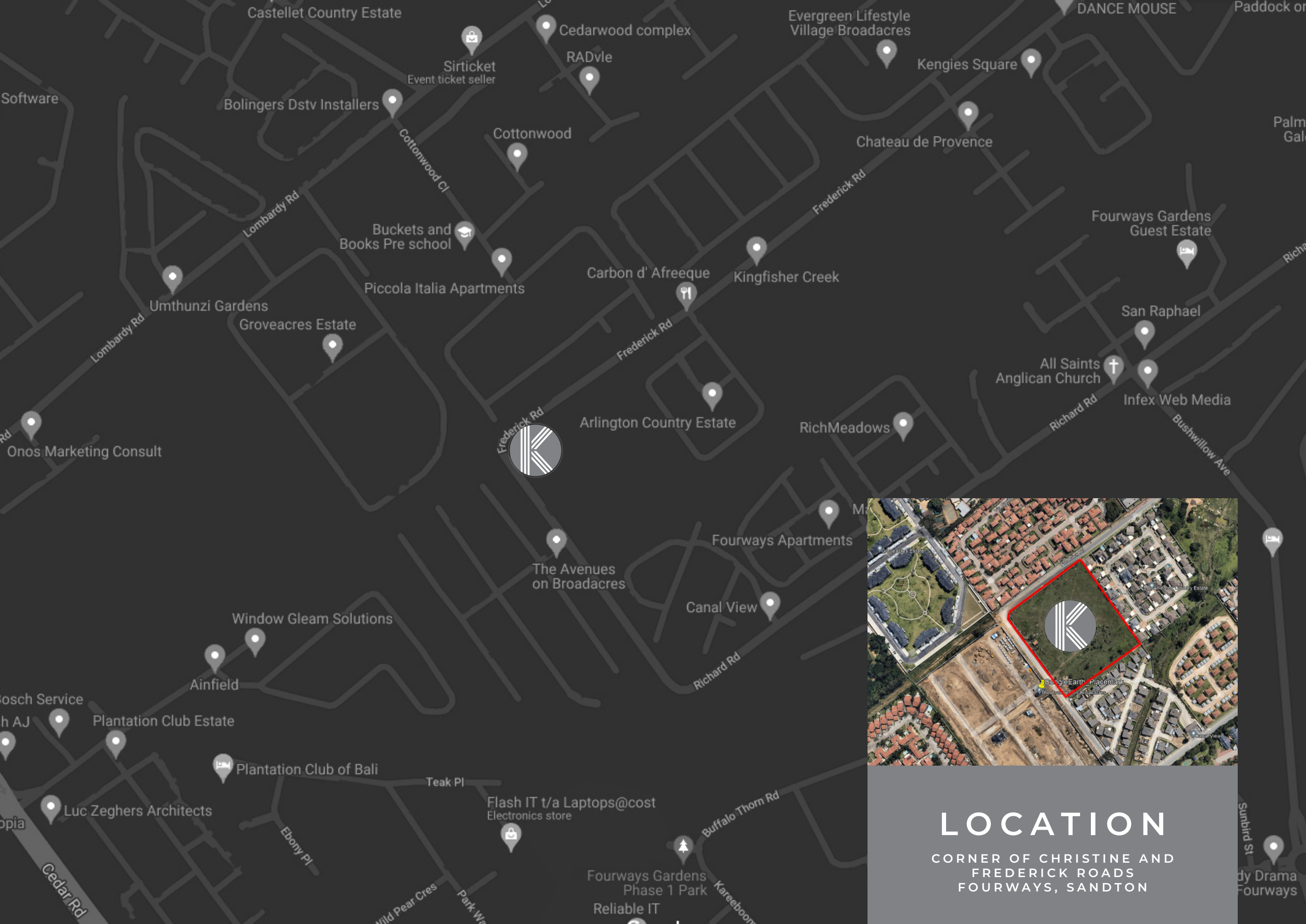

LOCATION

CORNER OF CHRISTINE AND
FREDERICK ROADS
FOURWAYS, SANDTON



BIRD'S EYE
VIEW



THE KINGSLEY

secure private estate





THE KINGSLEY

secure private estate





THE KINGSLEY

secure private estate

HOUSE PLAN TYPE A

3 BEDROOM | 3 BATHROOM
DOUBLE GARAGE

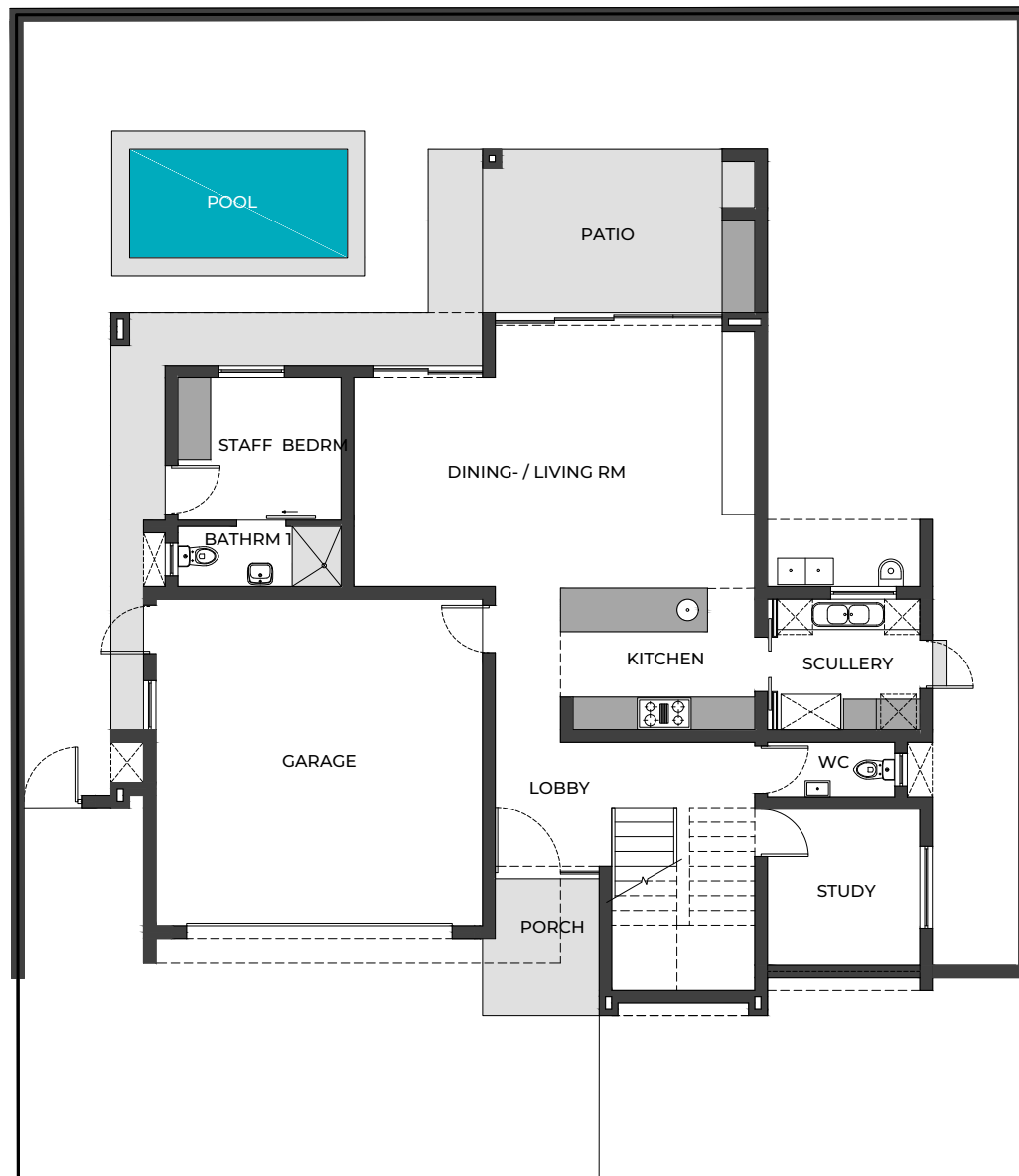

GROUND FLOOR

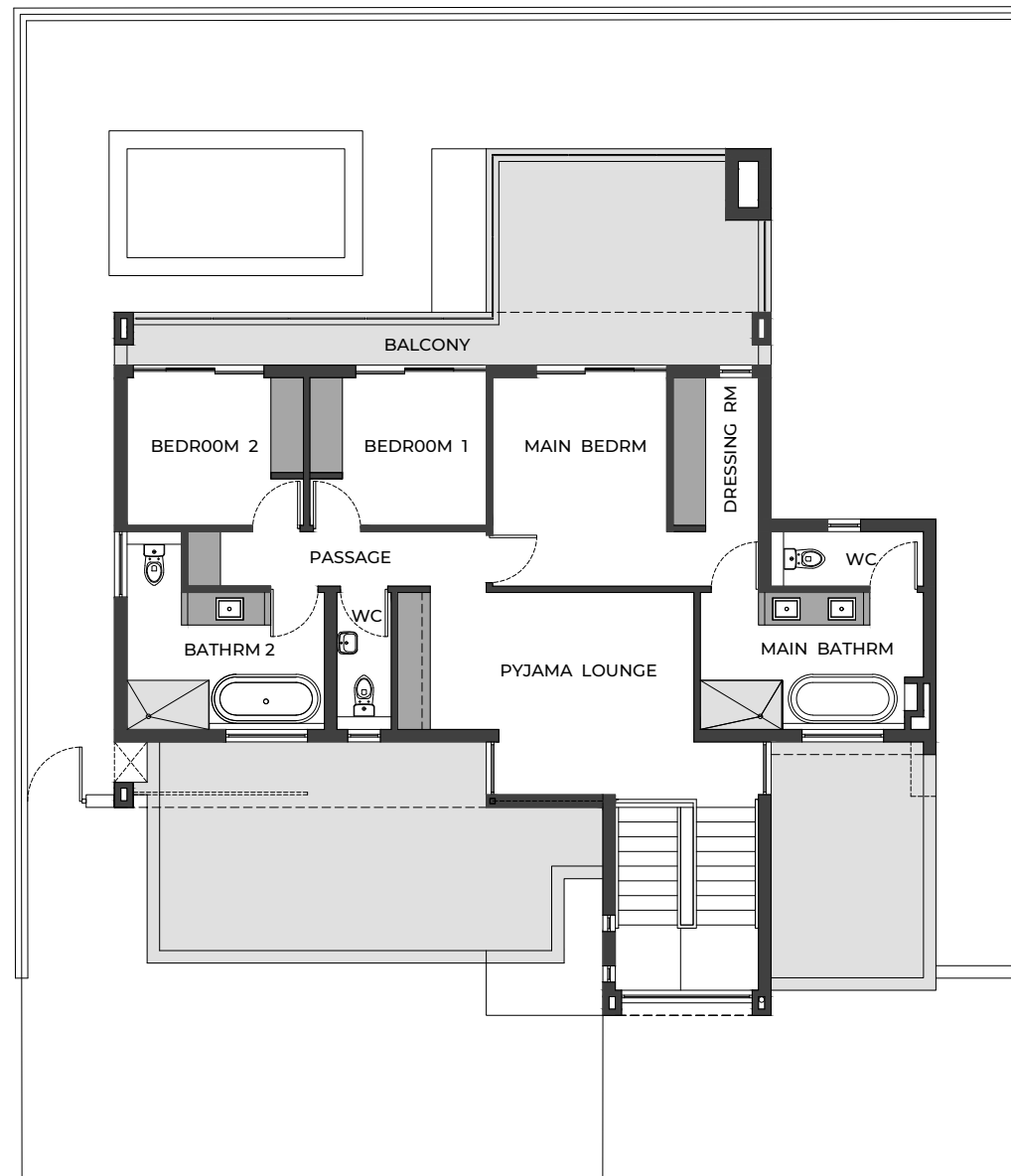

FIRST FLOOR

GROUND FLOOR	168 m²
Dining- Living Room	33 m ²
Kitchen	15 m ²
Scullery	7 m ²
Lobby	17 m ²
Guest WC	2,3 m ²
Study	9 m ²
Staff Bedroom	8 m ²
Staff Bathroom	3,3 m ²
Garage	36 m ²
Patio	13 m ²
Porch	2,5 m ²

FIRST FLOOR	114 m²
Pyjama Lounge	20 m ²
Passage	5 m ²
Main Bedroom	12 m ²
Main Bathroom	13 m ²
Dressing Room	6 m ²
Bedroom 1	9 m ²
Bedroom 2	9 m ²
Bathroom 2	10,5 m ²
WC	2,5 m ²
Balcony	22 m ²

TOTAL 282 m²

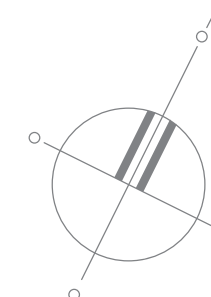



THE KINGSLEY

secure private estate

HOUSE PLAN TYPE B

3 BEDROOM | 3 BATHROOM
DOUBLE GARAGE

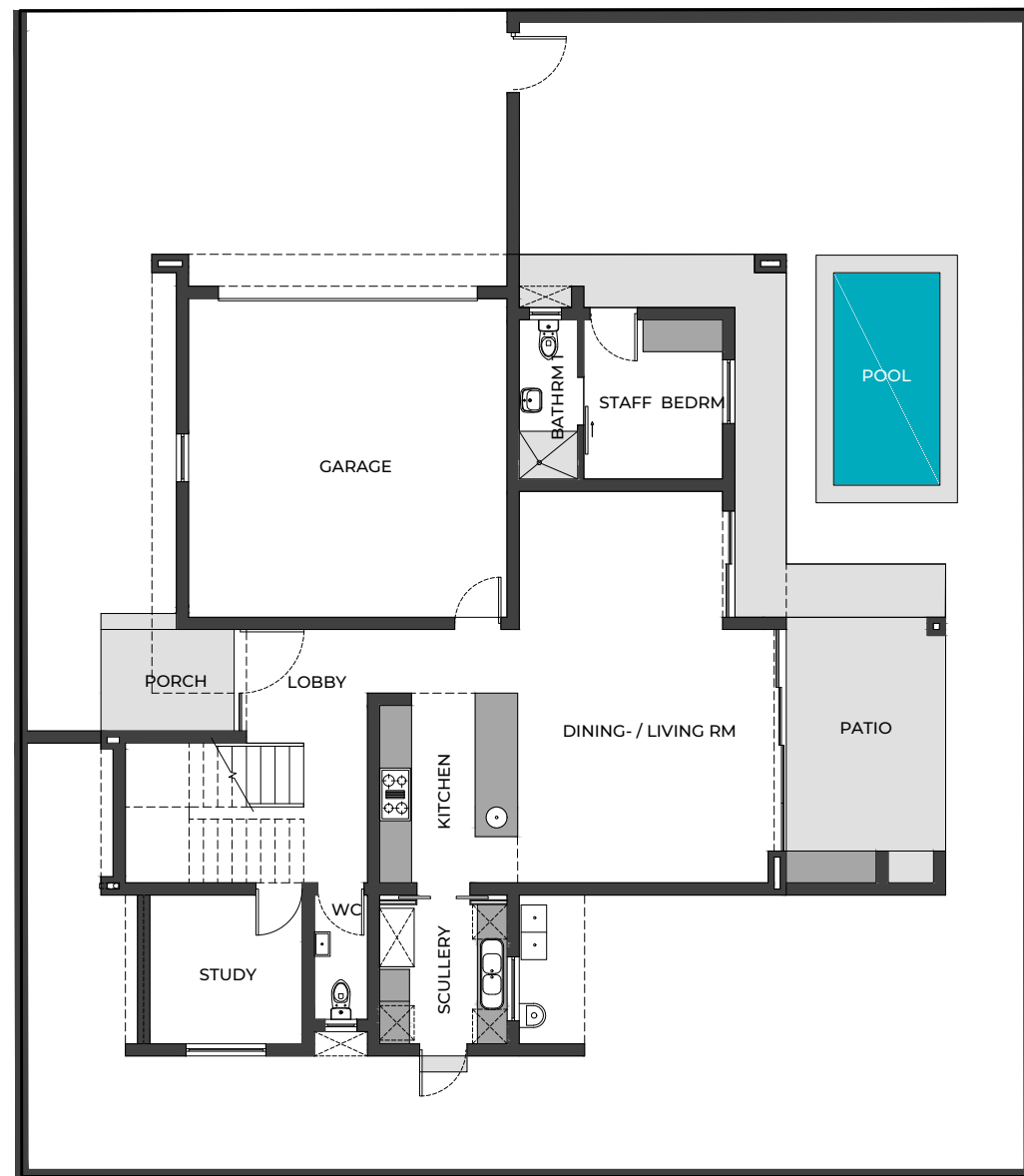

GROUND FLOOR

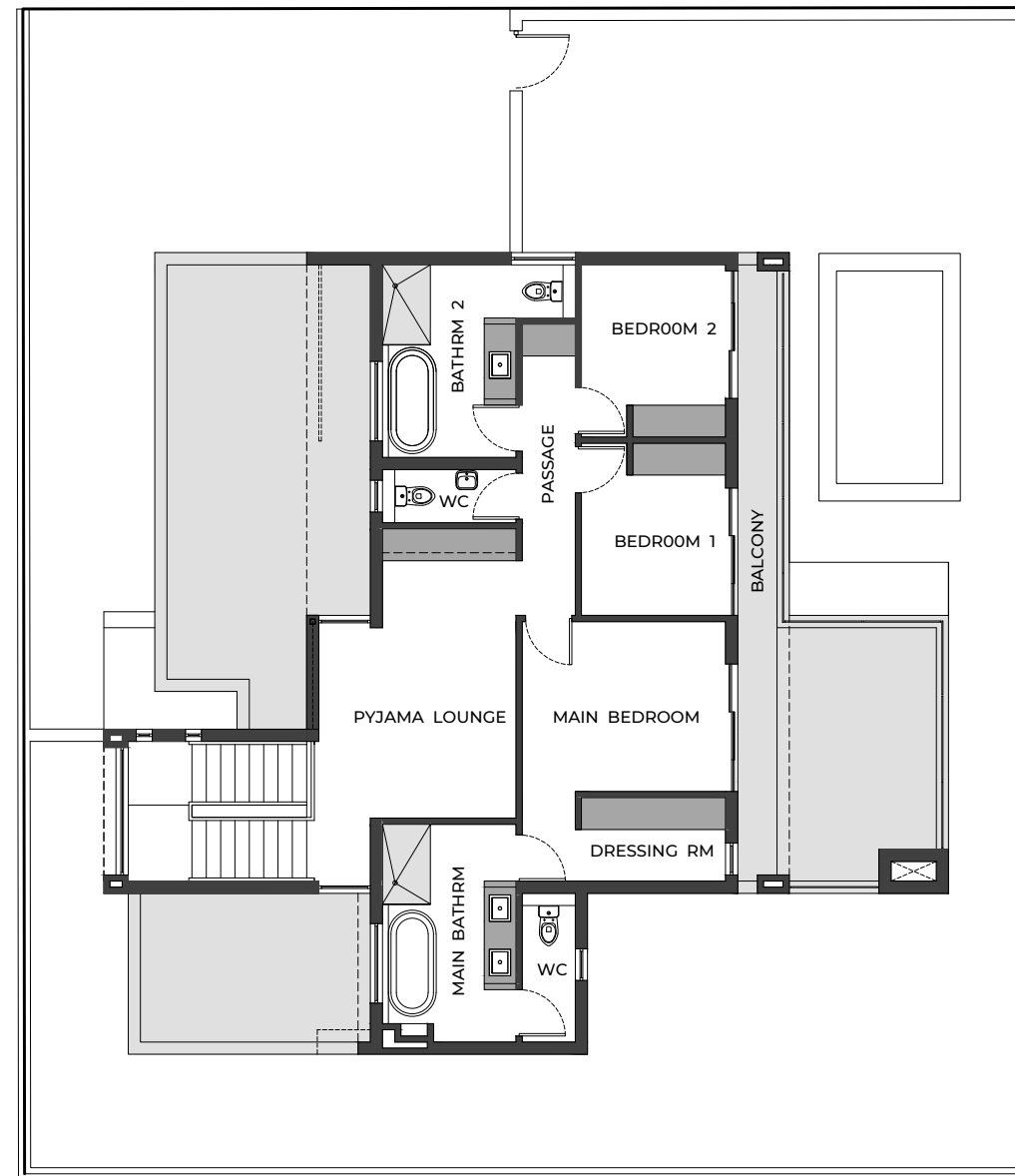

FIRST FLOOR

GROUND FLOOR	168 m²
Dining- Living Room	33 m ²
Kitchen	15 m ²
Scullery	7 m ²
Lobby	17 m ²
Guest WC	2,3 m ²
Study	9 m ²
Staff Bedroom	8 m ²
Staff Bathroom	3,3 m ²
Garage	36 m ²
Patio	13 m ²
Porch	2,5 m ²
FIRST FLOOR	114 m²
Pyjama Lounge	20 m ²
Passage	5 m ²
Main Bedroom	12 m ²
Main Bathroom	13 m ²
Dressing Room	6 m ²
Bedroom 1	9 m ²
Bedroom 2	9 m ²
Bathroom 2	10,5 m ²
WC	2,5 m ²
Balcony	22 m ²
TOTAL	282 m²

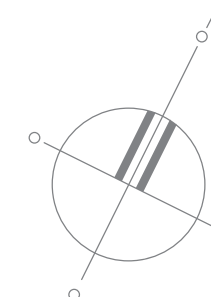



THE KINGSLEY

secure private estate

HOUSE PLAN TYPE C

3 BEDROOM | 3 BATHROOM
DOUBLE GARAGE

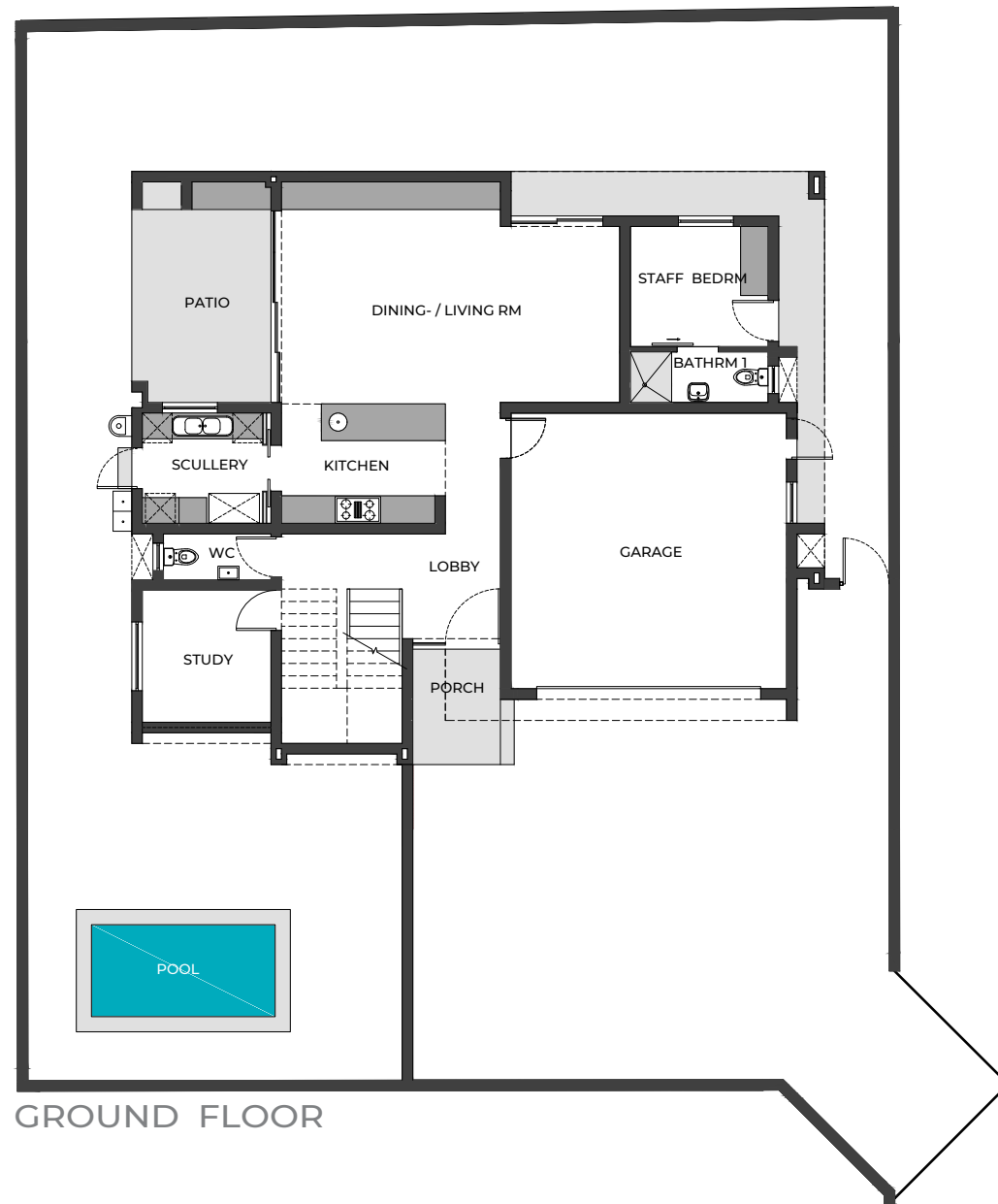

GROUND FLOOR

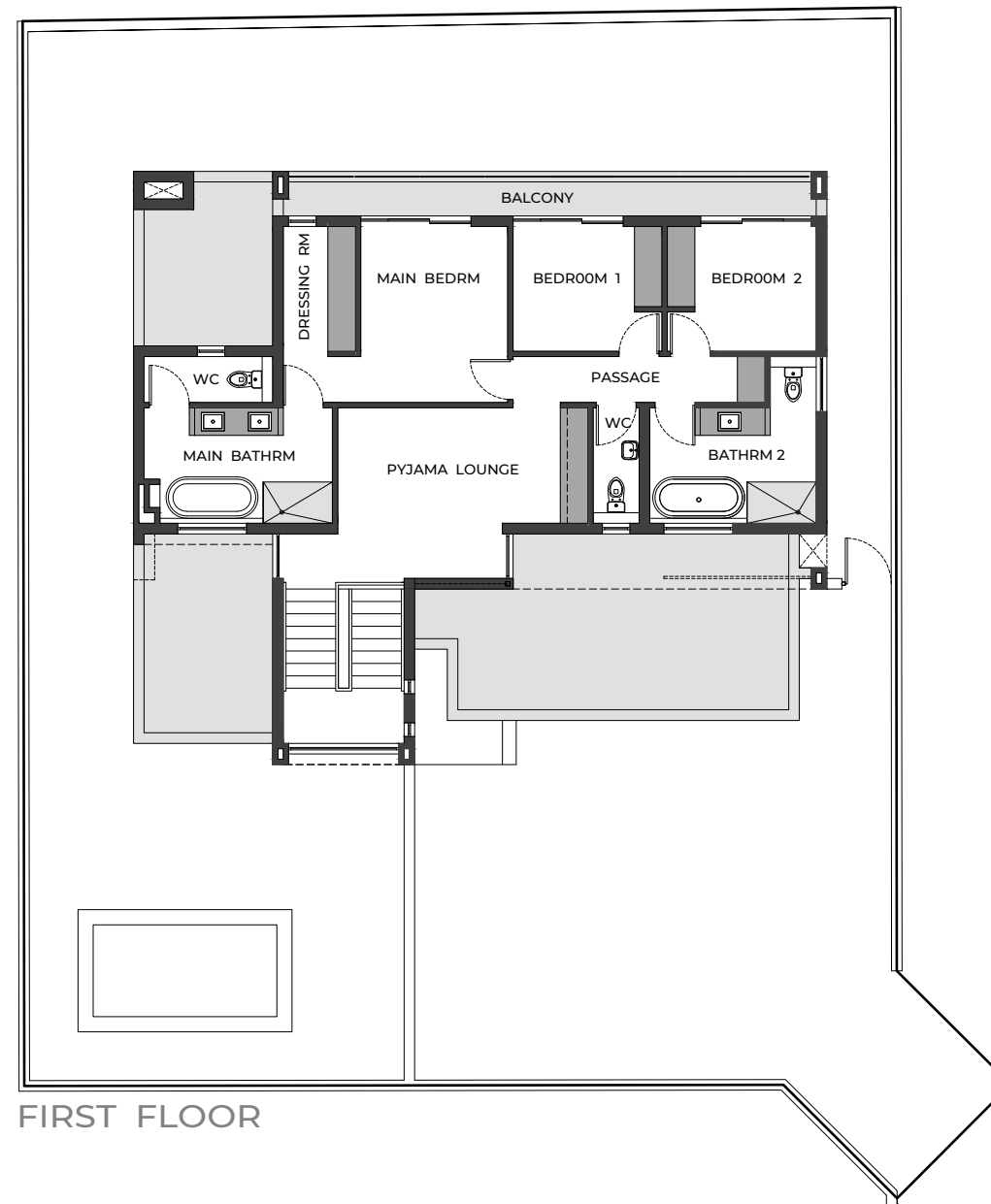

FIRST FLOOR

GROUND FLOOR	168 m²
Dining- Living Room	33 m ²
Kitchen	15 m ²
Scullery	7 m ²
Lobby	17 m ²
Guest WC	2,3 m ²
Study	9 m ²
Staff Bedroom	8 m ²
Staff Bathroom	3,3 m ²
Garage	36 m ²
Patio	13 m ²
Porch	2,5 m ²
FIRST FLOOR	114 m²
Pyjama Lounge	20 m ²
Passage	5 m ²
Main Bedroom	12 m ²
Main Bathroom	13 m ²
Dressing Room	6 m ²
Bedroom 1	9 m ²
Bedroom 2	9 m ²
Bathroom 2	10,5 m ²
WC	2,5 m ²
Balcony	22 m ²
TOTAL	282 m²

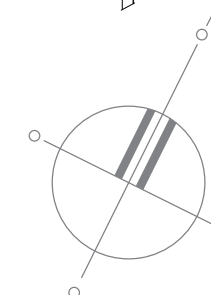



THE KINGSLEY

secure private estate

HOUSE PLAN TYPE D

3 BEDROOM | 3 BATHROOM
DOUBLE GARAGE

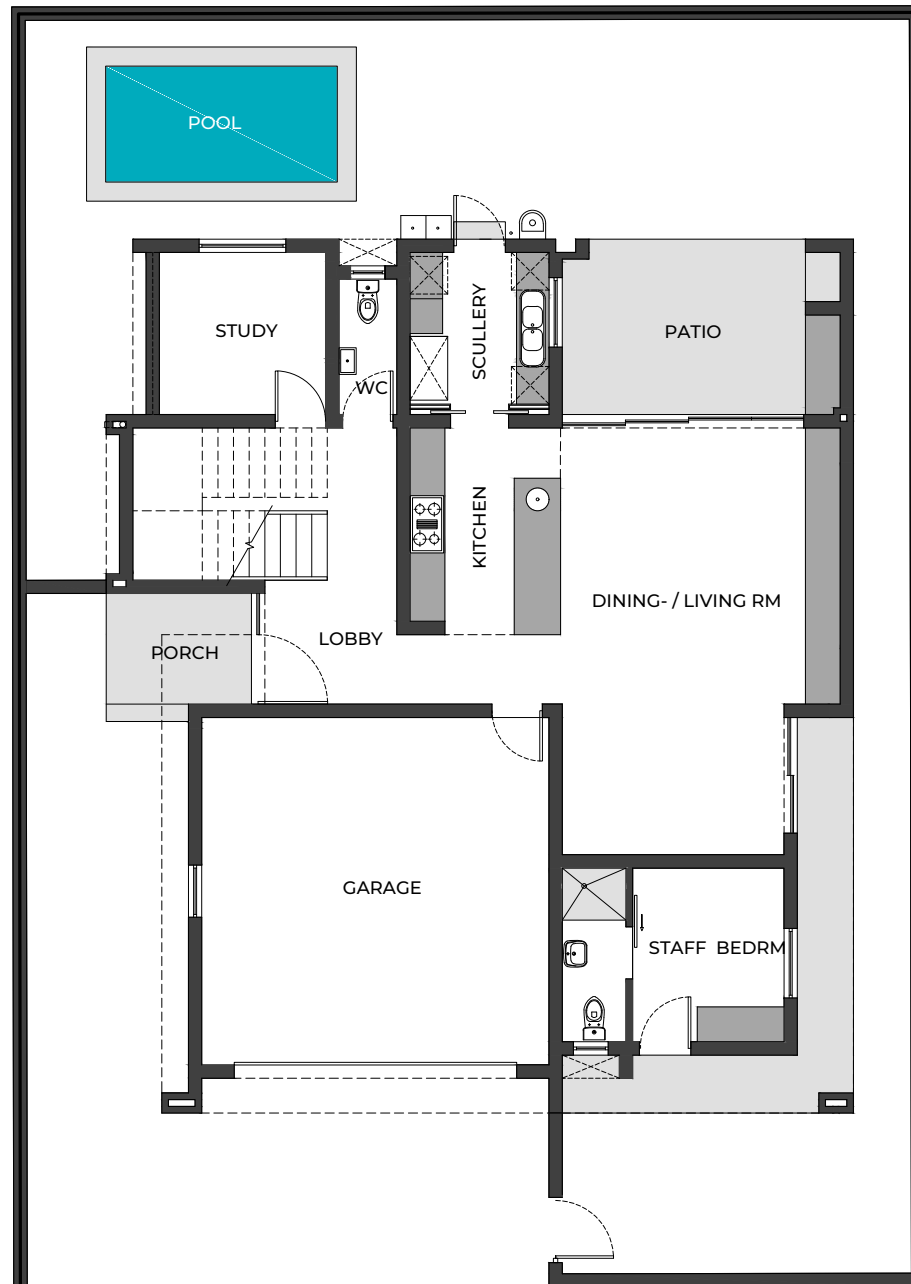

GROUND FLOOR

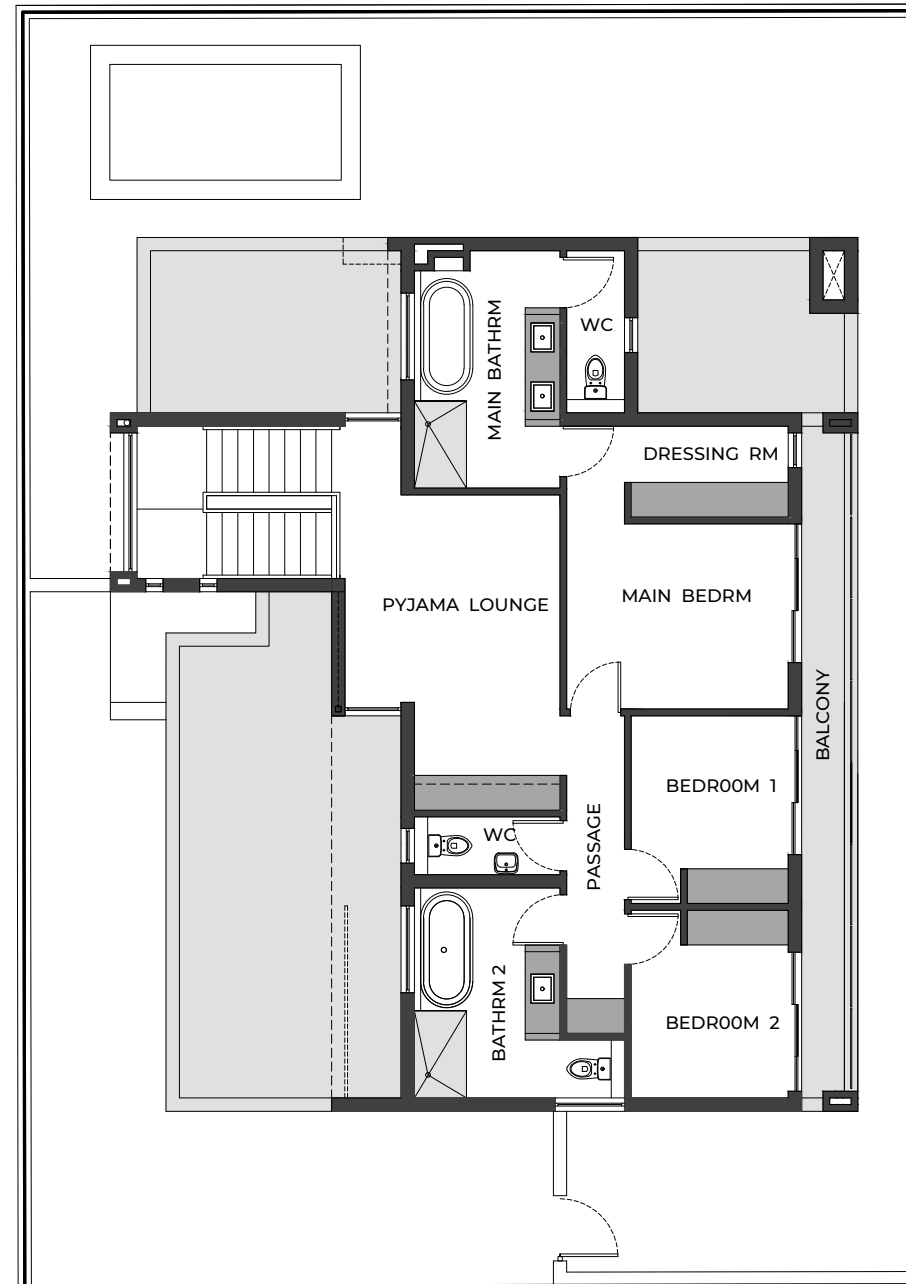

FIRST FLOOR

GROUND FLOOR	168 m²
Dining- Living Room	33 m ²
Kitchen	15 m ²
Scullery	7 m ²
Lobby	17 m ²
Guest WC	2,3 m ²
Study	9 m ²
Staff Bedroom	8 m ²
Staff Bathroom	3,3 m ²
Garage	36 m ²
Patio	13 m ²
Porch	2,5 m ²
FIRST FLOOR	114 m²
Pyjama Lounge	20 m ²
Passage	5 m ²
Main Bedroom	12 m ²
Main Bathroom	13 m ²
Dressing Room	6 m ²
Bedroom 1	9 m ²
Bedroom 2	9 m ²
Bathroom 2	10,5 m ²
WC	2,5 m ²
Balcony	22 m ²
TOTAL	282 m²

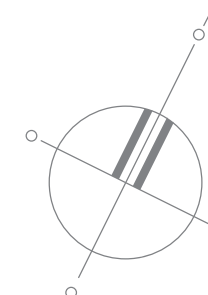



THE KINGSLEY

secure private estate





THE KINGSLEY

secure private estate





THE KINGSLEY

secure private estate





THE KINGSLEY

secure private estate

HOUSE FINISHES

WALLS

Interior: Clay brick, plastered and painted with one coat Sabre Plaster Skim and two coats Trend Matt Acrylic washable.

Exterior: Clay brick, plastered and painted with one coat Trend Plaster Primer and two coats of Trend Sand Exterior paint. (Colour as per architect spec)

ROOF Concrete Slab - CSS Rib & Block system
Waterproof Alcolin Slurry

WINDOWS Charcoal powder coated aluminium as per plan.
Glass type: clear float glass

DOOR FRAMES Exterior - Aluminium as per plan
Interior - Wood 70 x 45 x 813 no cill painted
Patios - Charcoal powder coated aluminium

DOORS Front Door - 38 mm Aluminium Charcoal with side light and skylight -
T Cranked handle 32 x 150 x 400mm



Back Door / Staff Room - Charcoal Aluminium Door

Interior Door - Hollowcore horizontal grooved door / painted



Fire door - Wood - Commercial Veneer Horizontal ½ Hr Fire Door / painted
Patio door - Charcoal powder coated aluminium as per plan

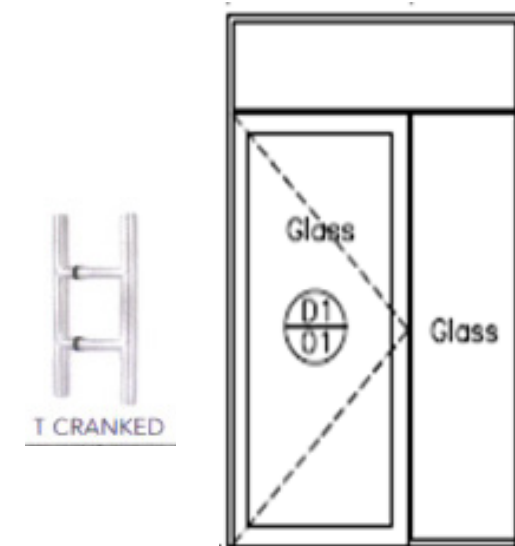



THE KINGSLEY

secure private estate

HOUSE FINISHES

IRONMONGERY Front door handle – Stainless Steel Pull handle – T Cranked 32 x 150 x 400 mm
Back doors – 2 lever locks with handles
Internal doors – 2 lever locks with Coupé Oulu Stainless Steel 16 mm(diameter)Leber handle on plate



CEILINGS Underside of decks skimmed and painted white with TS2 Cornice



SANITARY WARE White throughout

BATH Aquarius Bliss White Acrylic Freestanding Bath – 1725x795x630 mm with and clicker waste



TOILETS DIPLOMAT WHI Eco-Suite with concealed cistern and Glam Polished Chrome dual flush plate



BASINS Guest toilet Laufen Pro S White Wall Hung Basin with clicker waste (left of right)



Rhine Ceramic C/T Basin - on top basin for bathrooms with clicker waste





THE KINGSLEY

secure private estate

HOUSE FINISHES

SHOWER

Chrome Shower arm 400mm with round Shower Rose 200mm and Lucy Stainless Steel Shower Waste



SHOWER DOORS Frameless walkin shower, layout as per plan

TAPS

All internal taps to be mixers
Kitchen - Tivoli Pella Sink Mixer Chrome (Sink and prep bowl)

Bathrooms

Tivoli Pella Chrome Basin Mixer

Tivoli Pella Chrome Shower Mixer

Tivoli Pella Chrome Bath Mixer with with Elite Chrome Bath Spout 240mm



BATHROOM ACCESSORIES

Semplice Chiara Stainless Steel Toilet roll holder

Semplice Chiara Single Towel Hook - Guest Toilet

Semplice Chiara Single Towel Hook - Showers

Semplice Chiara Stainless Steel Double Towel Rail (800 mm)

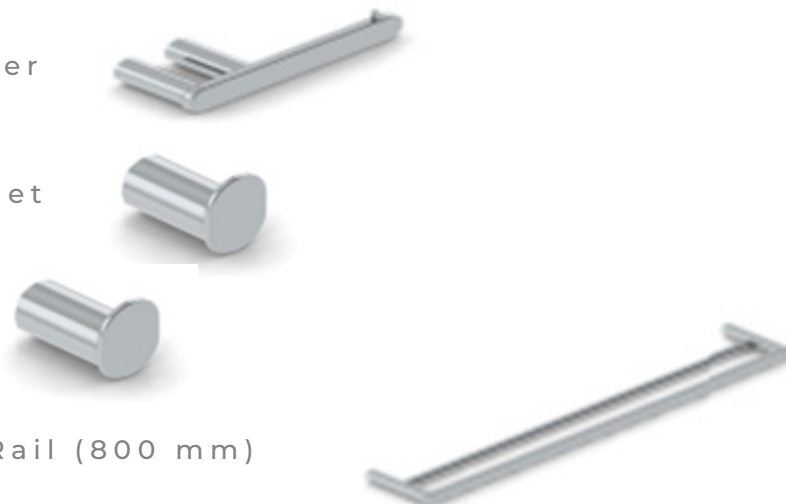



THE KINGSLEY

secure private estate

HOUSE FINISHES

GEYSER 200L Heat Tech Geyser B-Rated with 3.6 KW Domestic Heat pump R410A
SINK Franke Nouveau Double Sink and 2 Strainer Wastes 1160 x 460 mm



PREP BOWL Franke Cub 150 Prep Bowl with 1 basket strainer waste 450 x 161 mm



OUTSIDE WASH TROUGH Single Washtrough 540 x 440 mm

GENERAL Washing machine point (cold water)
Dishwasher point (cold water)

FLOOR AND WALL COVERING

WALL TILES Bathroom: 300mm splashbacks to basin and wall behind bath
Shower walls: Tiled up to 1.8m above floor - porcelain tiles.
Shower floor: 100 x 100 mm (same as floor tiles)
Choices from supplied moodboards (Italtile or Tiletoria)

Kitchen: 300 x 100 mm above cupboard counter tops
From Developer's preferred supplier. Choices from supplied moodboards

FLOOR TILES Porcelain - 600 x 600 mm to kitchen, bathroom(s), living areas, stairs, PJ Lounge, Passage and Patio
From Developer's preferred supplier. Choices from supplied moodboards

VINYL Bedrooms only
From Developer's preferred supplier (Italtile or Tiletoria)
Choice from supplied moodboards and samples

SKIRTING 20 mm x 140 mm (SK6) skirting to all rooms, except bathroom(s) and kitchen, painted





THE KINGSLEY

secure private estate

HOUSE FINISHES

CUPBOARDS

KITCHEN

Cupboards as indicated on plan
16 mm Novolam Melamine Hi Impact doors, 16 mm White Melamine interior and backing
Ball bearing runners
Handles allowed at R30.00 each
Counter Tops - Selection of Eazi Quartz Magnolia
Finishing Hight 2400 mm Standard Hight

BEDROOM

Cupboards is indicated on plan
16 mm Novolam Melamine Hi Impact doors, 16 mm White Melamine interior and backing
Ball bearing runners
Handles allowed at R30.00 each
Finishing Hight 2400 mm standard Hight

LIGHT FITTINGS Down lighters ground floor under deck as per plan (White)



OUTSIDE LIGHTS Up/Down Lighter (Stainless steel)

GLOBES

1. LED Globes - Colour: Warm White
2. Garage light: Double fluorescent Tubes
3. Scullery light: Double fluorescent Tubes in casing

OVEN AND HOB Defy electric oven with thermo fan DBO 475 (silver)



Defy 5 burner gas hob DHG 129 (silver)



Defy extractor DCH 318 (silver)





THE KINGSLEY

secure private estate

HOUSE FINISHES

TELEPHONE/TV AND ELECTRICAL POINTS	As per plan		
BRAAI	800 mm Build in Steel Braai - Black		
GATE	1.8 m (H) x 1.0 m (W) White Gate with White Powder coated Stainless Steel Hinges & Double Latch – Absolute Fencing		
PERIMETER WALLS	Private Fencing 1.8 m high – Absolute Fencing		
DRIVEWAY AND ENTRANCE	Paving as per plan. Cement bond pavers Charcoal and grey		
GARAGE	Steel sectional (or similar) automation Walls plastered, skimmed and painted		
GARDEN	Garden taps with wall bracket as per plan		
LANDSCAPING	Site levelled and cleared of rubble Lawn to front and back of house		
INCLUDED	Transfer duty not payable (VAT included in price) Architectural fees for typical unit plans Plan approval fees NHBRC Fees Water connection Electrical connection	NOT INCLUDED	Transfer fees Bond registration fees Curtain rails Washing line Swimming Pool (optional extra)

TGP Construction Gauteng will notify you at an appropriate time during the construction of your new home, to choose the following finishes as per the supplied moodboards on site - Tiles, Cupboards & Vinyl (Bedrooms)
You will have 10 working days in which to make your selection. If no selection is confirmed with TGP's head office in this time then it will be accepted that the finishes as per developer's choice are to be used.

GENERAL

1. These specifications serve as a guideline only and the Contractor reserves the right to amend and/or substitute items, at its sole discretion.
2. The employer is not permitted to do any work on site while construction is under way without the permission of T G P Construction Gauteng (Pty) Ltd.
3. All PC amounts in this specification are inclusive of VAT.
4. Settlement cracks are regarded as a maintenance item and are not covered under the contractor's guarantee.
5. Foundations are designed in accordance with a geotechnical report.

NOTE

Should the specifications contained herein differ from the specifications in the final plans or construction drawings, then this specification will be the final ruling document, subject to substitution envisioned in clause 1 above.

I/we the purchaser/s have read and understand the Finishing schedule as set out above in Schedule B and acknowledge the content thereof.

I/we accept the content and understand that these items are included in the purchasing price and any alterations to this will be at an additional cost on written request.

Further hereby the purchaser/s also confirms that the Finishes as per the Moodboards are included in the purchase price.



THE KINGSLEY

secure private estate

Harcourts
Capital

CONTACT



DENNIS HAMER

082 415 8547

dennis.h@harcourts.co.za